

PT-10-FB RS-485

COMPUTER CONTROLLED PAN & TILT UNIT



RS-485 / RS-232 computer controlled for advanced features and control options

Real-time position feedback, variable rotation speed, variable braking, and networkability of multiple pan and tilts

10 lb-ft (13.56 N-m) of output torque on each axis and accommodates payloads up to 25 lbs (11.3 kg)



Rugged pan and tilt unit with RS-485 / RS-232 computer control to remotely orient camera systems, acoustic equipment, antennas, and other instrumentation.

The PT-10-FB RS-485 pan and tilt provides 10 lb-ft (13.56 N-m) of output torque on each axis. Heavy-duty ball bearings supporting the output shaft allow it to accommodate payloads up to 25 lbs (11.3 kg). Each axis includes a DC brushless stepper motor coupled to low backlash harmonic gearing. It is designed to allow stalling of the output shafts without damage to the gears, the motors, or control electronics.

The RS-485 / RS-232 control enables the pan and tilts to be highly configurable and precision controllable. By using either the ROS positioner GUI (graphical user interface) or the ROS communication protocol for custom software integration you can control unique features such as: variable rotation speed, real-time position feedback, variable braking, programmable software limits, and networkability of multiple ROS pan and tilts sharing the same cable. A total of only four wires (two for power; two for communication) are needed to operate the RS-485 / RS-232 pan and tilt units.

Using RS-485 control provides several advantages over RS-232. RS-485 allows communication over longer lengths of cable (1000 feet) and enables the ability for networking multiple nodes. A typical computer has the capability of RS-232 communication through its serial COM ports. Inexpensive devices are readily available for converting RS-232 to RS-485, USB to RS-485, or Ethernet to RS-485. This unit may also be controlled by an external joystick.

The PT-10-FB RS-485 pan and tilt is available in two versions: air-filled or oil-filled. Oil-filled units are used for deep water applications up to 3,000 meters depth. Air-filled units are used for shallow water applications up to 30 meters depth. In addition, air-filled units are suitable for above water applications where rain, humidity, and dust are issues.

PT-10-FB RS-485 Computer Controlled Pan & Tilt Unit

PERFORMANCE

Power:

Operating Range: 24 - 28 VDC, 1.5 amps (max) per axis @ 24 VDC
 Braking Mode: 24 VDC, adjustable, 0 mA to 750 mA per axis
 At Rest (not braking): < 100 mA per axis

Torque:

10 lb-ft (13.56 N-m) per axis, 0.5 to 15 degrees/second (0.08 to 2.5 RPM)
 8 lb-ft (10.85 N-m) per axis, 15 to 20 degrees/second (2.5 to 3.3 RPM)
 Variable, 0.5 to 20 degrees/second (0.08 to 3.3 RPM)

Rotation Speed (88:1 gears):

0.6 degrees (36 arc minutes)

Harmonic gear backlash (88:1 gears):

0 to 360 degrees when used with no external stop collar

Scan Range (both axes):

12 to 348 degrees pan axis, +/- 90 degrees tilt axis

Scan Range with stop collar & optional yoke bracket:

Absolute position (1000 ohm wire-wound), 10 bit A/D

Feedback Potentiometer:

+/- 0.5 degrees (30 arc minutes)

Resolution:

Control protocol:

Type:

RS-485, 2-wire half duplex, 8 data bits, 1 stop bit, no parity, no hardware flow control

Command Protocol:

ROS Document 21-30022

Supported Baud Rates:

Factory set to 9.6 Kbaud, 19.2 Kbaud, or 57.6 Kbaud

Networkability:

Up to 32 ROS RS-485 nodes sharing the same cable for power and communication

MECHANICAL

Housing Material:

Anodized 6061-T6 Aluminum

Electropolished 316 Stainless Steel

Height:

236 mm (9.30 in)

236 mm (9.30 in)

Width:

Air-filled:

179 mm (7.05 in)

179 mm (7.05 in)

Oil-filled with bellofram:

219 mm (8.64 in)

219 mm (8.64 in)

Length without connector:

94.0 mm (3.70 in)

94.0 mm (3.70 in)

Main Body Diameter:

74.9 mm (2.95 in)

74.9 mm (2.95 in)

Output Shaft Diameter:

25.4 mm (1.00 in)

25.4 mm (1.00 in)

Weight in Air:

Air-filled:

3.7 kg (8.2 lbs)

6.2 kg (13.6 lbs)

Oil-filled:

4.4 kg (9.6 lbs)

7.0 kg (15.5 lbs)

Weight in Water:

Air-filled:

2.2 kg (4.8 lbs)

4.4 kg (9.7 lbs)

Oil-filled:

4.2 kg (9.3 lbs)

8.1 kg (17.8 lbs)

Standard Connector:

LPMBH-4-MP

Housing Mounting:

Two 1/4-20 threaded holes in output pan shaft

Equipment Mounting:

Two 1/4-20 threaded holes in output tilt shaft

Mounts:

ROS mounting plate and optional yoke bracket

External Mechanical Limits:

ROS stop collar

Compensator (oil-filled units only):

Bellofram

ENVIRONMENTAL

Operating Depth Rating:

Air-filled:

30 m (100 ft)

Oil-filled:

3,000 m (10,000 ft)

Operating Temperature:

up to +50°C (122°F)

Storage Temperature:

-20°C to +60°C (-4°F to 140°F) in air

ROS STANDARD PIN-OUT

1 - DC COMMON

2 - +24 VDC

3 - RS-485 A

4 - RS-485 B

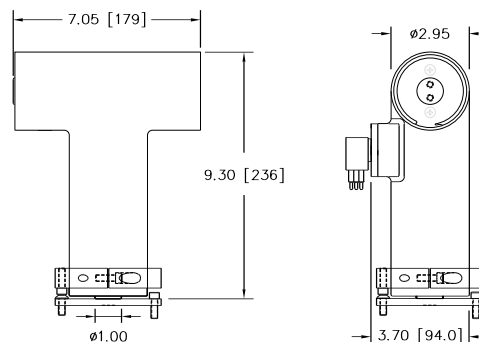
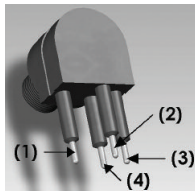

5618 Copley Drive
 San Diego, CA 92111 USA
 Tel (858) 565-8500
 Fax (858) 565-8808
 East Coast Office (804) 754-3936

www.rosys.com
sales@rosys.com